

# V.H.R.<sup>®</sup>



## Hand chain block for load from 250 to 10000 kg

 **VERLINDE**  
LIFTING EQUIPMENT

2, boulevard de l'Industrie - B.P. 20059 - 28509 Vernouillet cedex - France

Tel. : (33) 02 37 38 95 95 - Fax : (33) 02 37 38 95 99

Internet : [www.verlinde.com](http://www.verlinde.com)

01 2005 111 U GB

# V.H.R.<sup>®</sup>

## Hand chain block for load from 250 to 10000 kg

### GENERAL CHARACTERISTICS

- Machined chain sprocket and gears provide smoother, more efficient operation.
- Overload limiting device to prevent lifting loads beyond rated capacity (except 250kg unit.).
- 3 meters standard lift. Hand chain is 0.5 meters less than lift.  
Non-standard lifts available.
- High strength grade 80 alloy steel load chain with galvanized finish for corrosion resistance (comply with EN 818, safety factor 4).
- VHR's compact design offers safety together with reduced weight. Ideal for construction and maintenance applications.
- Rugged construction featuring steel gearcase and handwheel cover.
- ISO hooks are alloy steel, heat treated and equipped with hook latches and inspection points.



### TECHNICAL CHARACTERISTICS - DIMENSIONS

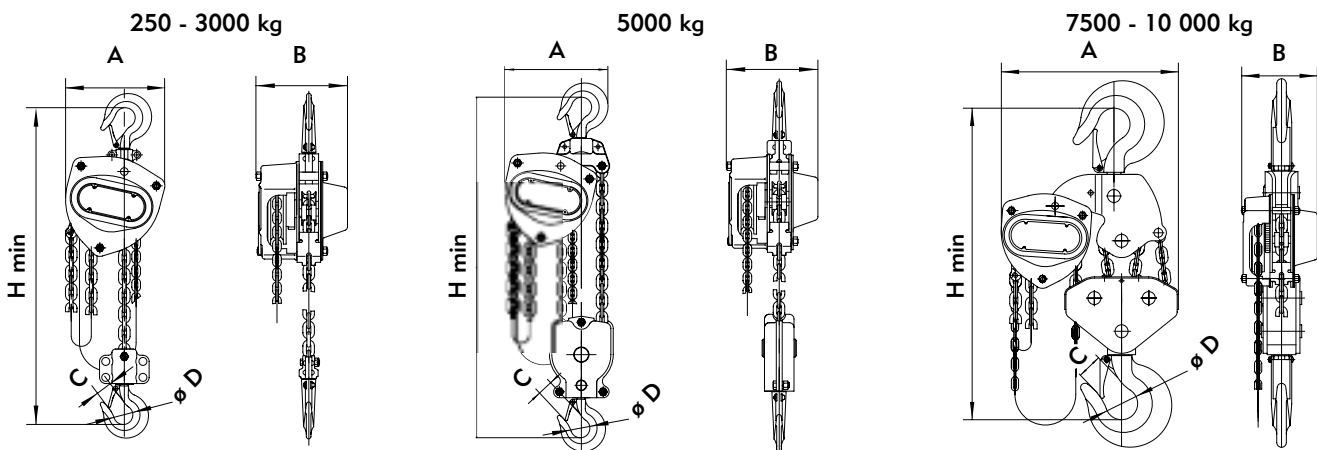

Type	Load (kg)	Height of lift (m)	Load chain		Pulling force (kg)	Net weight (kg)	Size				
			Falls	ø x pitch			A (mm)	B (mm)	C (mm)	D (mm)	H min (mm)
VHR 1	250	3	1	4x12	23	6.2	121	114	21	31	280
VHR 2	500	3	1	5x15	24	11	148	132	23	35	345
VHR 3	1000	3	1	6x18	25	12.5	172	151	27	40	376
VHR 4	1500	3	1	7.1x21	26	17.8	196	173	33	45	442
VHR 5	2000	3	1	8x24	33	19.5	210	175	35	50	470
VHR 6	3000	3	1	10x28	37	35	255	205	39	55	548
VHR 7	5000	3	2	9x27	36	41.3	280	189	45	65	688
VHR 8	7500	3	4	9x27	38	78.5	463	189	54	75	765
VHR 9	10000	3	4	9x27	38	78.5	463	189	54	75	765

\* From 500 kg



2, boulevard de l'Industrie - B.P. 20059 - 28509 Vernouillet cedex - France  
Tel. : (33) 02 37 38 95 95 - Fax : (33) 02 37 38 95 99

Internet : [www.verlinde.com](http://www.verlinde.com)

01 2005 111 U GB