

MANUAL WINCHES

ME - MV



**for lifting and traction
from 150 to 3000 kg**

 **VERLINDE**
LIFTING EQUIPMENT

2, boulevard de l'Industrie - B.P. 59 - 28501 Vernouillet cedex - France
Phone : (33) 02 37 38 95 95 - Fax : (33) 02 37 38 95 99
Internet : www.verlinde.fr
X 03 2002 11 U GB

WORM-GEARED HAND-OPERATED WINCH

T Y P E
MV

High degree of protection

The very rigid tubular frame is coated with heavy-duty chlorinated rubber paint. The mechanical parts together with the drum are protected by cataphoresis.

Easy fastening with four points well distributed, providing balanced anchoring.

Mechanism

Breaking and endurance tests have been made on the wheel and endless worm thus providing maximum reliability. The hubs are machined to provide a grease space. The automatic ratchet brake with stainless steel spring is the most well-tried system.

Adjusting button

Very comfortable to use, the crank handle adjusting cranking button is, moreover, captive.

Declutchable drum

Except on the 250 kg model. The MV winches are fitted with a declutchable drum, via a small and easily accessible lever. A safety device prevents any declutching when the winch is loaded.

Safety

In view of perfect safety of the users and protection of the mechanism, the MV drums are fitted with a fairing that can be easily removed.

Rope fastener

Very safe and universal, it requires no tool and offers great flexibility in the choice of ropes*.

* Rope not supplied with the winch.

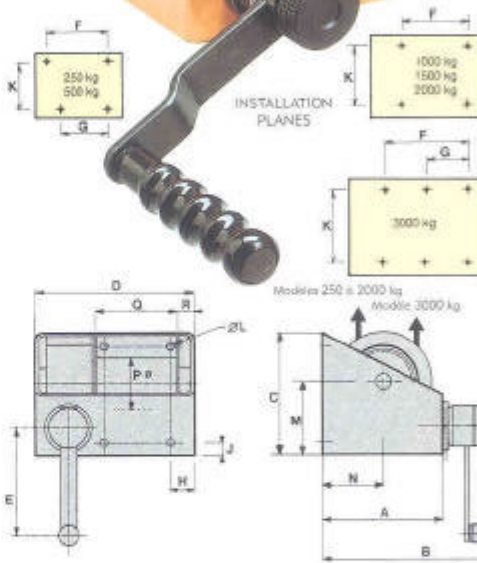

MAX. F.
RATED
Crank
Crank w.
mic, res.
coated
table pl.
of the ar.
ted pro.
mum for
ding of t.
(mm) load

Force kg	A	B	C	D	E	F	G	H	J	K	Ø L	M	N	Ø P	Q	R
250	190	330	150	200	250	137	100	25	15	118	4 Ø 11	89	75	60	180	24
500	180	360	180	260	250	182	130	32	18	142	4 Ø 13	109	90	70	145	30
1000	300	490	300	300	340	167	-	32	21	250	4 Ø 17	180	146	101	176	30
1500	300	490	300	300	340	167	-	32	21	250	4 Ø 17	180	146	101	176	30
2000	345	540	345	405	340	260	-	40	25	295	4 Ø 21	222	168	121	275	40
3000	525	700	460	510	340	390	195	70	40	380	6 Ø 25	325	173	168	300	55

Force kg	No. of speeds	Rope			Force on crank handle kg	Lift per turn of crank handle mm	Weight without rope kg
		Ø mm	Max. capacity m	Nb. of layers			
250*	1	5	20	4	11	21	10
500	1	6,8	25	4	12	15	15
1000	1	8	35	4	14	12	35
1500	2	11,5	20	3	12	7	39
2000	2	13	30	3	15	6	61
3000	2	15	40	3	12	4	145

* The 250 kg winch does not possess a declutchable drum.

HAND-OPERATED GEARING TYPE WINCH

T Y P E
ME

High degree of protection
Extremely rigid tubular frame, coated with heavy-duty chlorinated rubber paint. The mechanical parts together with the drum are protected by cataphoresis.



RCE

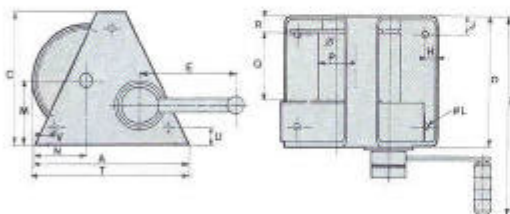
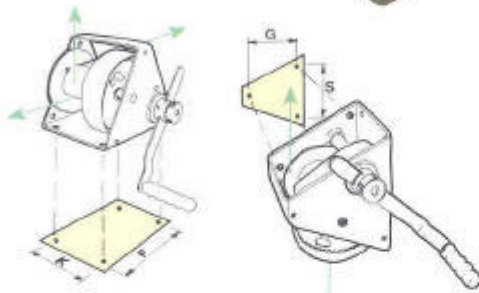

Fastening of the winch
The ME winch has a horizontal fastening plane in 4 points and for the 150 kg, 300 kg, 500 kg models, a second vertical fastening plane. These winches are therefore designed for numerous applications.

Mechanism
All the breaking and endurance tests have been applied to the gearing, the hubs are machined to provide a grease space. The automatic ratchet brake with stainless steel spring is the most well-tried system for this type of equipment.



Declutchable drum
Declutchable via a small and easily accessible safety lever. An exclusive safety device prevents any declutching when the winch is loaded.



Rope fastener
Very safe and universal, it requires no special tool and provides great flexibility in the choice.
* Rope not supplied



Captive adjusting button
Very comfortable to use, it adjusts the crank handle or removes it in order to lock the winch.

Force kg	A	B	C	D	E	F	G	H	J	K	ØL	M	N	ØP	Q	R	S	T	U	Y
150	180	325	190	158	380	144	104	13	18	114	7 Ø 9	75	85	555	67	43	130	-	18	24
300	240	385	200	200	200	135	20	28	144	7 Ø 13	76	84	75	107	25	184	150	23	28	
500	340	385	200	200	230	135	20	28	144	7 Ø 13	76	84	75	107	25	184	200	23	28	
1000	412	485	300	300	330	370	-	21	22	236	4 Ø 17	145	138	101	176	25	-	423	-	
2000	500	385	325	405	350	440	-	30	40	325	4 Ø 21	155	143	121	276	-	-	515	-	

Force kg	Nb of speeds	Rope			Force on crank handle kg	Lift per turn of crank handle mm	Weight without rope kg
		Ø mm	Max. capacity m	Nb of layers			
150	1	4	22	6	15	185	8
300	1	6	40	6	10	35	16
500	1	6.8	20	4	13	35	18
1000	1	9	30	4	12	24	38
2000	1	13	30	3	13	13	80

consolidation et renforcement sous réserve de modifications.

advice as to the use of hand-operated winches

recommandations for pulling or traction operation



2, boulevard de l'Industrie - B.P. 59 - 28501 Vernouillet cedex - France
Téléphone : (33) 02 37 38 95 95 - Télécopieur : (33) 02 37 38 95 99
Internet : www.verlinda.fr
N° 01200 11 11 GB

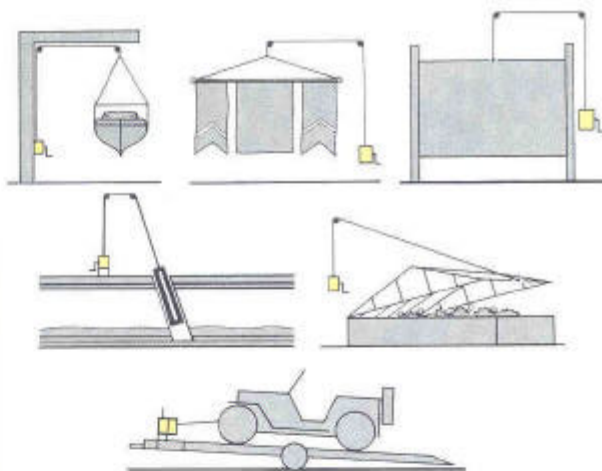

- The **MV** worm-gear and **ME** gearing type hand-operated winches have been designed to meet all the requirements of the lifting and traction market. This type of winch can be used either for hoisting, with all the safety measures necessary to comply with existing standards, or for "traction or pulling" with the same sturdiness as hoisting.

NB : The tractive capacity shown is valid for a unit operating under optimum conditions.

Important : Three turns of rope should always remain wound on the drum at the end of travel. Winches are delivered without rope as standard.



During traction, the tension on the rope should never exceed the winch's rated lifting load capacity.

- **Optimum working conditions:**
Calculation of the load which can be travelled varies according to the conditions of the installation, considering the following parameters:
 - whether or not the wheels are mounted on ball bearings
 - diameter of the wheels (the larger the diameter the less the pull)
 - the materials of which the wheel is made and what it runs on determines the travelling coefficient (rail, wood, asphalt, concrete or sand) and the slope, if any.

DISTRIBUTED BY

